



Awning enclosure

Installation and usage instructions

EN

Markisenvorzelt

Montage- und Gebrauchsanleitung

DE

Auvent pour stores

Instructions de montage et mode d'emploi

FR

Cierre para toldos

Instrucciones de montaje y uso

ES

Chiusura per tendalini

Istruzioni di montaggio e d'uso

IT

Sluiting voor luifels

Montage- en gebruiksinstructies

NL

Stängning för markiser

Monterings- och bruksanvisning

SV

Lukning til markiser

Monterings- og brugsvejledning

DA

Lukking av markiser

Monterings- og bruksinstruksjoner

NO

Markiisien sulkulaite

Asennus- ja käyttöohjeet

FI

Fecho para toldos

Instruções de montagem e de uso

PT



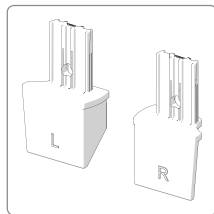
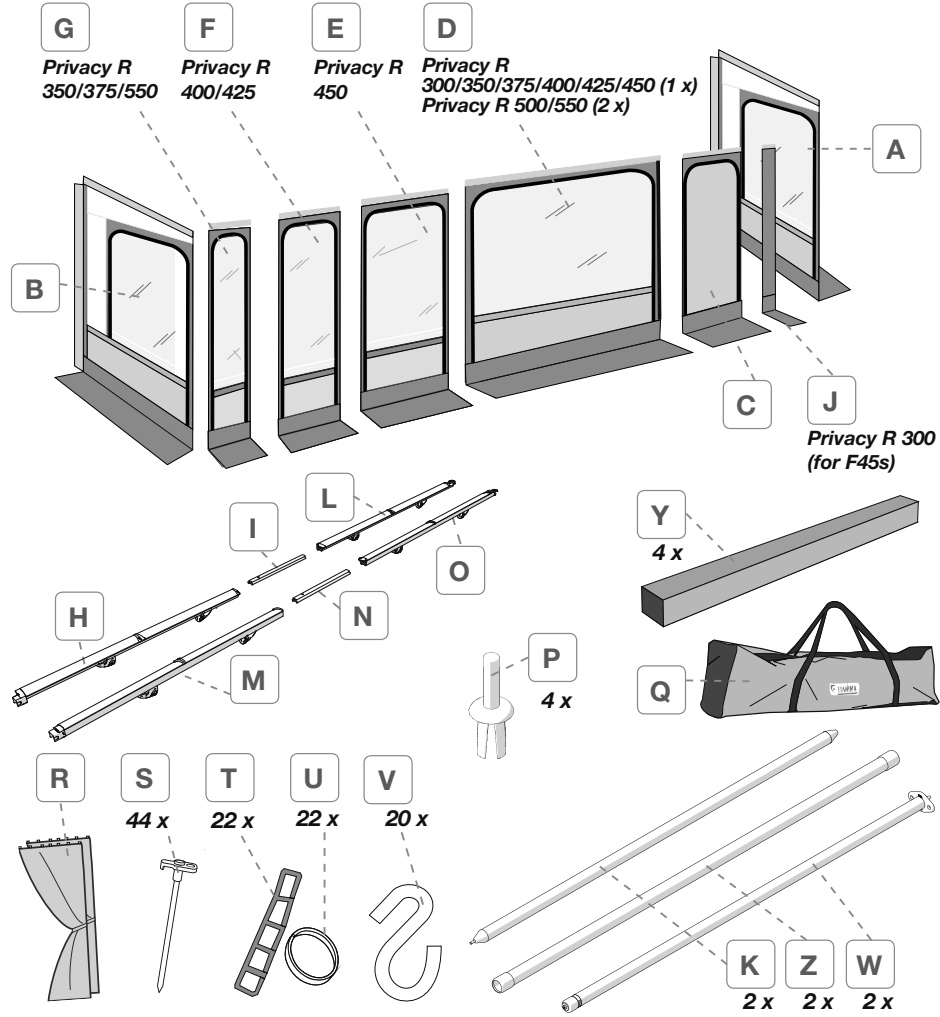

X1 98655-900
Kit F45 Ti 250-300
Only for Privacy R 300

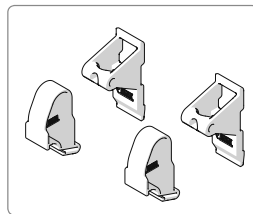

X2 98655-901 Kit Omnistor
4900/5002/5003 Tristor2

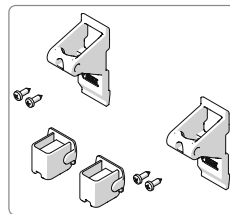

X3 98660-072
Kit F45 Ti/F45s

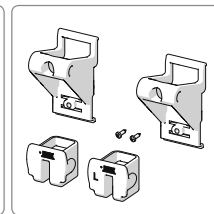

X4 98660-073
Kit F45 Ti L/F45L

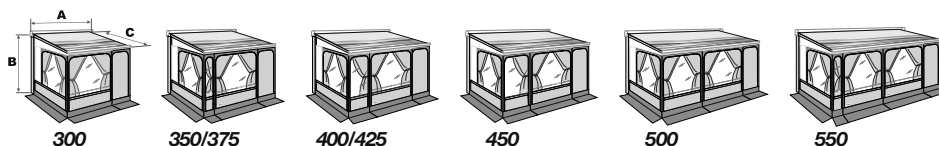

		A	B	C	
Privacy Room 300 Medium	07353-01-	300 cm	225-250 cm	250 cm	24,4 kg
Privacy Room 350 Medium	07353-02-	350 cm	225-250 cm	250 cm	24,9 kg
Privacy Room 375 Medium	07353-05-	375 cm	225-250 cm	250 cm	25,1 kg
Privacy Room 400 Medium	07353-03-	400 cm	225-250 cm	250 cm	25,4 kg
Privacy Room 425 Medium	07353-06-	425 cm	225-250 cm	250 cm	25,6 kg
Privacy Room 450 Medium	07353-04-	450 cm	225-250 cm	250 cm	25,9 kg
Privacy Room 300 Large	07353A01-	300 cm	251-280 cm	250 cm	24,7 kg
Privacy Room 350 Large	07353A02-	350 cm	251-280 cm	250 cm	25,2 kg
Privacy Room 375 Large	07353-07-	375 cm	251-280 cm	250 cm	25,4 kg
Privacy Room 400 Large	07353A03-	400 cm	251-280 cm	250 cm	25,7 kg
Privacy Room 425 Large	07353-08-	425 cm	251-280 cm	250 cm	26,0 kg
Privacy Room 450 Large	07353A04-	450 cm	251-280 cm	250 cm	26,2 kg
Privacy Room 500 Large	07353A05-	500 cm	251-280 cm	250 cm	26,7 kg
Privacy Room 550 Large	07353A06-	550 cm	251-280 cm	250 cm	27,2 kg

Package contents / Verpackungsinhalt / Contenu de l'emballage / Contenido del embalaje /
 Contenuto dell'imballo / Inhoud van de verpakking / Förpackningens innehåll / Pakkens indhold /
 Innholdet i pakningen / Pakkauksen sisältö / Conteúdo da embalagem **p. 2**

Installation instructions / Montageanleitung / Instructions de montage / Instrucciones de montaje /
 Istruzioni di montaggio / Montage-instructies / Monteringsanvisningar / Monteringsvejledning /
 Monteringsinstruksjoner / Asennusohjeet / Instruções de montagem **p. 4**

Instructions for use / Gebrauchsanleitung / Instructions d'installation / Instrucciones de uso /
 Istruzioni di utilizzo / Gebruiksaanlecties / Bruksanvisning / Brugsvejledning / Bruksinstruksjoner /
 Käyttöohjeet / Instruções de utilização **p. 10**

Safety instructions / Sicherheitshinweise / Consignes de sécurité / Instrucciones de seguridad /
 Avvertenze di sicurezza / Veiligheidswaarschuwingen / Säkerhetsföreskrifter / Sikkerhedsforan-
 staltninger / Sikkerhedsadvarsler / Turvallisuusvaroitukset / Advertências de segurança **p. 12**

Accessories / Zubehör / En option / Accesorios / Accessori / Benødigdheden / Tillbehör /
 Tilbehør / Tilbehør / Lisävarusteet / Acessórios **p. 23**

Warranty / Garantie / Garantie / Garantia / Garanzia / Garantie / Garanti / Garanti / Garanti /
 Takuu / Garantia **p. 23**



EN

Goods receipt inspection

Check that nothing has been damaged or deformed during transport.
In the event of doubts or questions concerning the installation, use or limitations of the product, contact the dealer.

DE

Kontrolle bei der Annahme

Bitte kontrollieren Sie, dass alle Einzelteile einwandfrei sind und nicht während dem Transport beschädigt wurden.
Im Zweifelsfall oder bei Fragen zur Montage, Verwendung oder zu Einschränkungen des Produkts wenden Sie sich bitte an Ihren Händler.

FR

Contrôle à la réception

Contrôler le contenu du colis et vérifier qu'aucune pièce n'ait été cassée ou déformée durant le transport.
En cas de doutes ou de questions relatives à l'installation, l'utilisation du produit, contactez votre concessionnaire.

ES

Control de recepción de mercancía

Controlar que ningún detalle se haya roto o deformado durante el transporte.
En caso de dudas o si tiene alguna pregunta sobre el montaje, uso y limitaciones del producto, póngase en contacto con el distribuidor.

IT

Controllo al ricevimento

Controllare che nessun particolare sia rotto o deformato a causa di errori di trasporto.
In caso di dubbi o domande relative al montaggio, utilizzo e limiti del prodotto, contattare il rivenditore.

NL

Controle bij ontvangst

Controleer of er geen onderdelen zijn gebroken of vervormd als gevolg van het transport.
Neem contact op met uw dealer als u vragen of opmerkingen hebt over de montage, het gebruik en de beperkingen van het product.

SV

Kontroll vid leverans

Kontrollera att inga delar har skadats eller deformerats under transporten. Kontakta försäljaren om du har frågor om monteringen, användningen och produktens gränser.

DA

Kontrol ved modtagelsen

Kontrollér, at ingen del er ødelagt eller deformeret grundet fejl under transport. I tvivlstilfælde, eller hvis du har spørgsmål vedrørende montering eller produktets brug og begrænsninger, bedes du kontakte forhandleren.

NO

Kontroll ved mottak

Kontroller at ingen deler er ødelagt eller deformert som følge av feil under transporten. Hvis du er i tvil eller har spørsmål knyttet til montering, bruk eller begrensninger for produktet, ta kontakt med forhandleren.

FI

Vastaanottotarkastus

Tarkasta, että mikään osa ei ole kuljetusvirheiden vuoksi rikkoutunut tai vääntynyt. Epäselvissä tapauksissa tai jos sinulla on tuotteen asennusta, käyttöä tai rajoituksia koskevia kysymyksiä, ota yhteys jälleenmyyjään.

PT

Controlo na receção do produto

Controlar que nenhuma peça tenha ficado partida ou deformada devido a erros de transporte.
Em caso de dúvida ou perguntas relativas à montagem, utilização e limites do produto, contactar o revendedor.

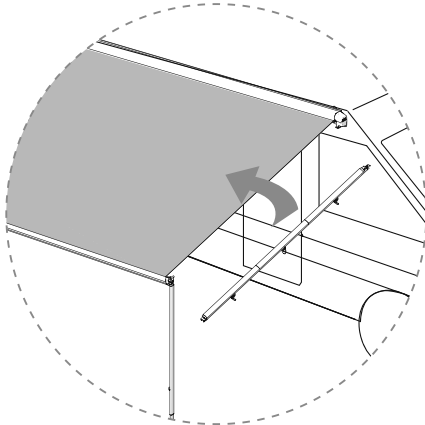

H I L M N O P



K Z W



X1 X2 X3 X4



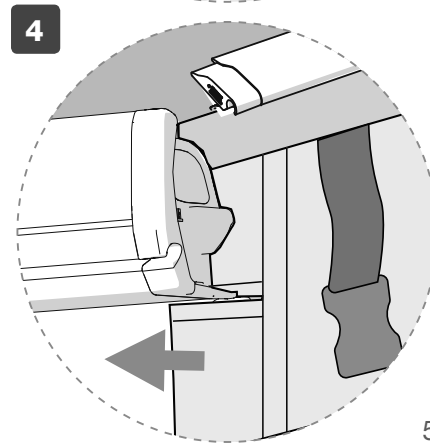
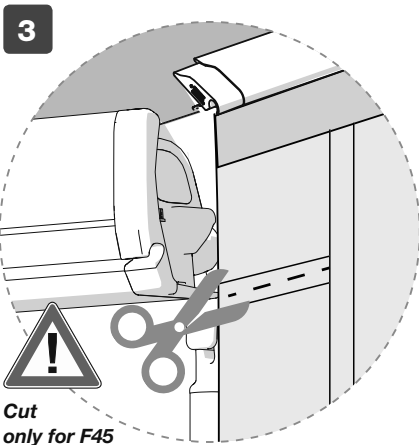
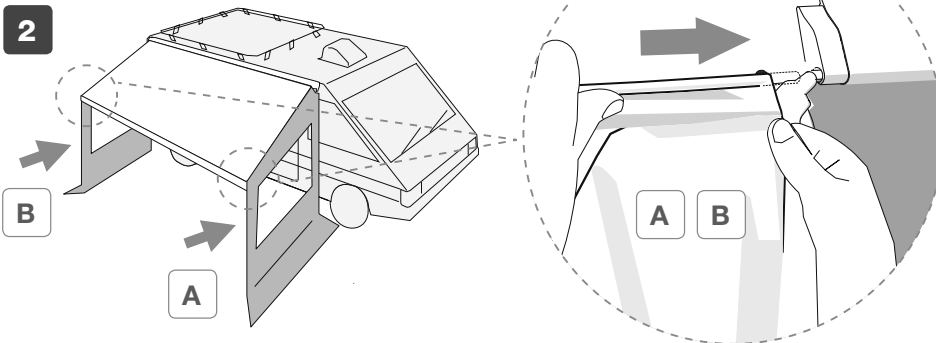
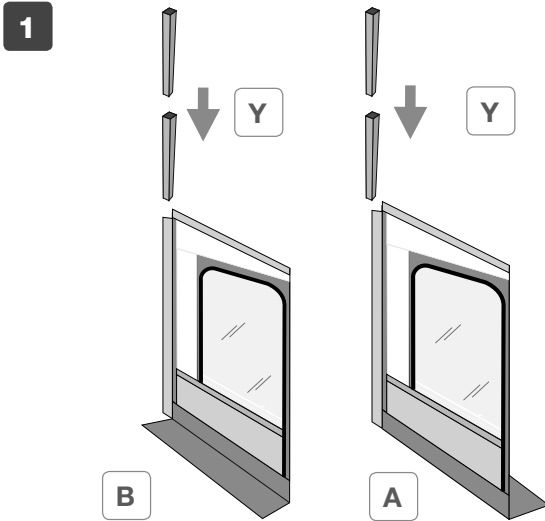



5

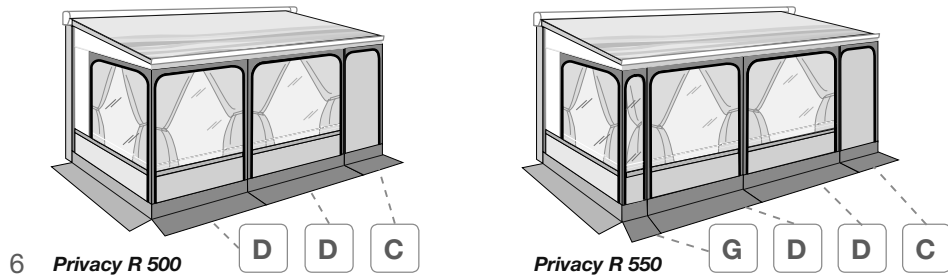
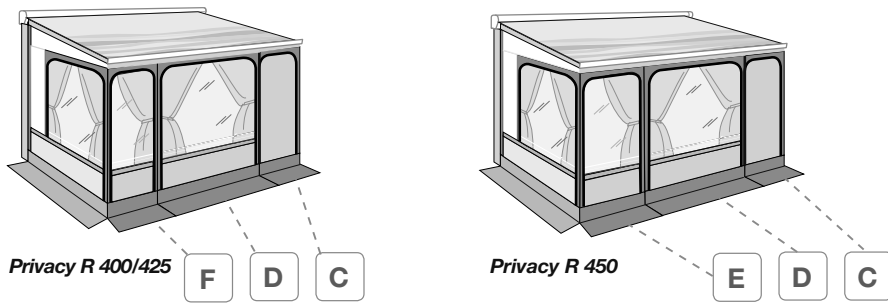
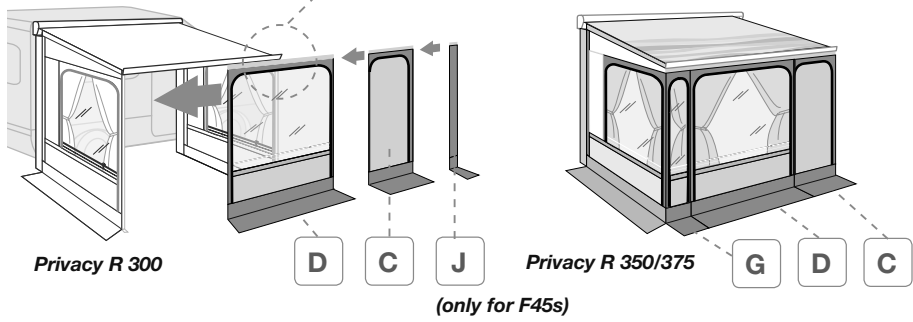
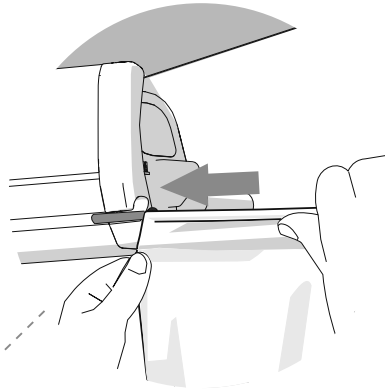

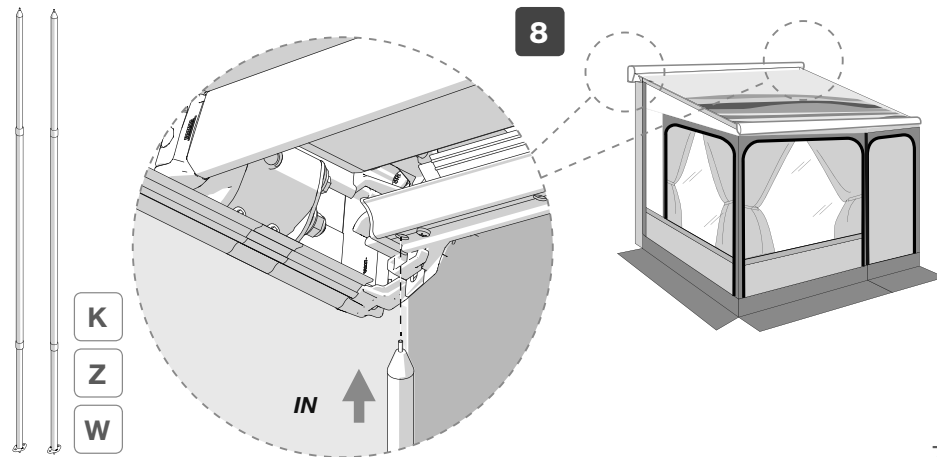
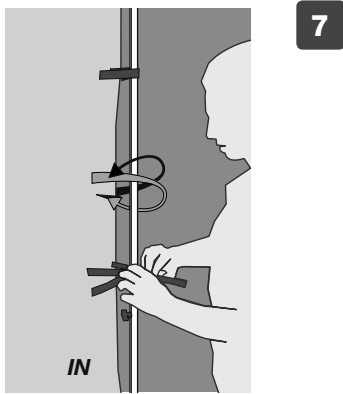
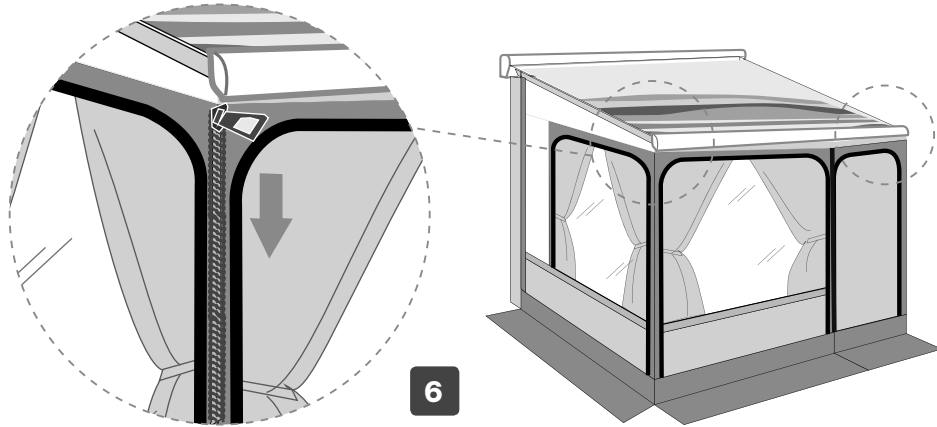

- EN** Before tapping, close the windows fastening them to the velcro at the bottom.
- DE** Schließen Sie die Fenster vor dem Abstecken, indem Sie sie unten am Klettverschluss befestigen.
- FR** Avant de planter les piquets, fermer et attacher les fenêtres à l'aide du velcro situé dans la partie inférieure.
- ES** Antes de montar, cerrar las ventanas sujetándolas al velcro en la parte inferior.
- IT** Prima di picchettare, chiudere le finestre fissandole al velcro nella parte inferiore.

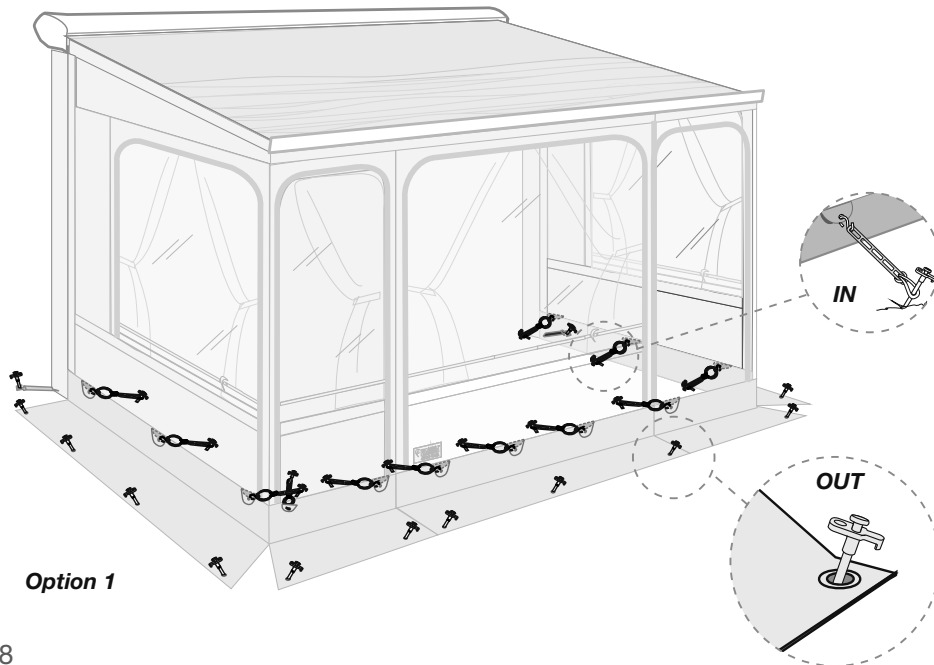
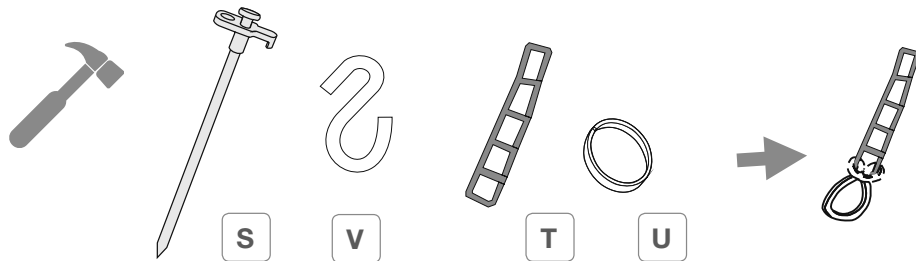

- NL** Sluit de ramen voor het plaatsen van piketten door ze aan de onderzijde aan het klittenband te bevestigen.
- SV** Innan du sätter upp stänger ska fönstren stängas genom att fästa dem till det nedre kardborrebandet.
- DA** Før pløkkerne slås i, skal vinduer lukkes ved at fastgøre dem på velcroen for neden.
- NO** Før du setter i pluggene må du lukke vinduene ved å feste dem med borrelåsene i den nedre delen.
- FI** Ennen paalutusta sulje ikkunat kiinnittäen ne alaosassa olevaan tarranauhaan.
- PT** Antes de tamborilar, fechar as janelas fixando-as no velcro na parte inferior.

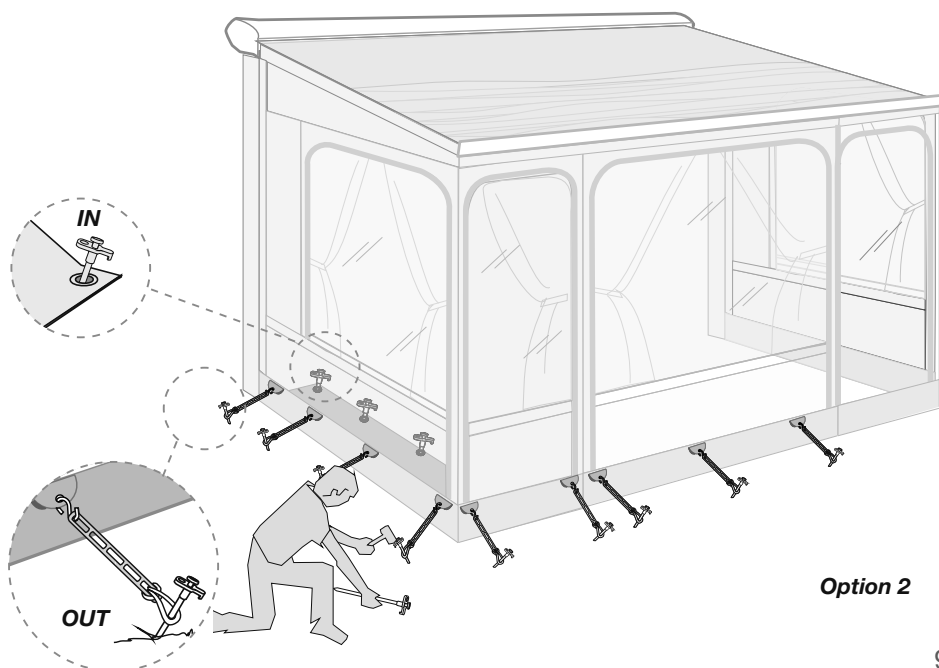

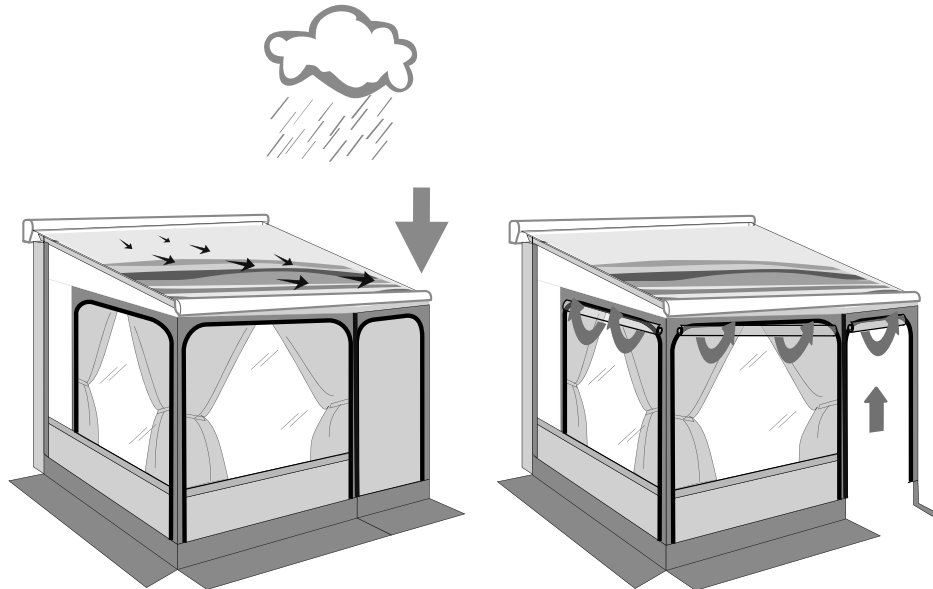

EN

In case of rain we recommend to lower a pole to allow the water to flow.

DE

Bei Regen ist es ratsam einen Stützfuß tiefer zu setzen, so dass ein Wasserabfluss ermöglicht wird.

FR

En cas de pluie, il est recommandé de baisser un pied du store pour que l'eau puisse s'écouler de l'autre côté.

ES

En caso de lluvia, es aconsejable bajar una pata para que el agua fluya.

IT

In caso di pioggia é consigliabile abbassare una palina per permettere all' acqua di defluire.

NL

In geval van regen is het raadzaam om een stok te laten zakken zodat het water kan wegstromen.

SV

Det rekommenderas att en stång sänks vid regn så att vattnet kan rinna av.

DA

Når det regner, anbefales det at sænke en af stængerne, så vandet kan løbe af.

NO

I tilfelle av regn anbefaler vi at du senker en av stengene for at vannet skal kunne renne bort.

FI

Sateen tapauksessa suositellaan laskemaan yhtä paalua, jotta vesi valua vapaasti.

PT

Em caso de chuva é aconselhável baixar uma estaca para permitir à água defluir.

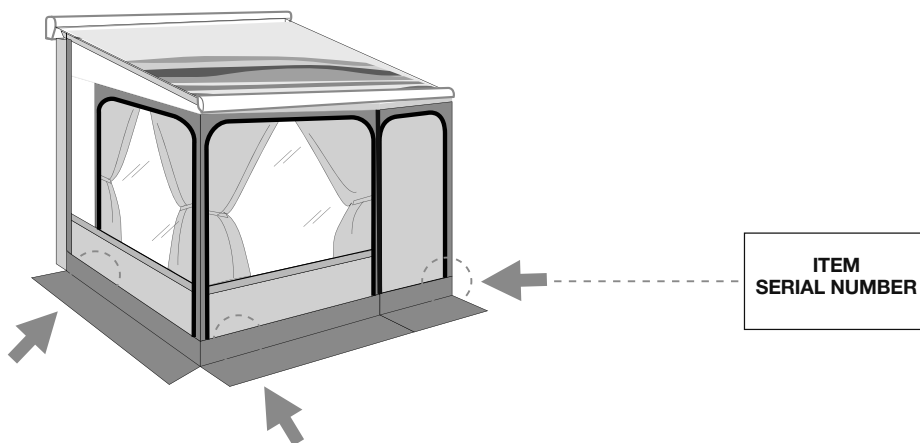

- | | |
|-----------|--|
| EN | In case of problems please contact your local dealer indicating the data on the nameplate. Consult our website for spare parts drawing. |
| DE | Bei Problemen bitte den Händler kontaktieren und die auf dem Etikett aufgeführten Daten mitteilen. Auf der Homepage finden Sie die Explosionszeichnung |
| FR | En cas de problème, contacter le revendeur et lui communiquer les informations reportées sur la plaquette. Consulter le site Internet pour une vue éclatée des pièces de rechange. |
| ES | En caso de cualquier problema, ponerse en contacto con su distribuidor local facilitando los datos sobre la placa. Consultar el sitio web para el despiece de los repuestos. |
| IT | In caso di problemi contattare il rivenditore di zona, comunicando i dati riportati sulla targhetta. Consultare il sito web per l'esplosivo ricambi. |
| NL | Raadpleeg uw lokale dealer in geval van problemen onder vermelding van de gegevens op het typeplaatje. Raadpleeg de website voor de detailtekening met onderdelen. |
| SV | Vid problem, kontakta en lokal återförsäljare och uppge uppgifterna som står på typskylten. Gå till webbplatsen för en sprängskiss över reservdelar. |
| DA | Kontakt din lokale forhandler i tilfælde af problemer, og angiv oplysningerne på skiltet. Rådfør med webstedet for listen over reservedele. |
| NO | Ved problemer ta kontakt med den lokale forhandleren, og oppgi informasjonen på merkeplaten. Se nettsidene for detaljert tegning av reservedelene. |
| FI | Mikäli ilmenee ongelmia, ota yhteys alueen jälleenmyyjään ja ilmoita kilvessä olevat tiedot. Varaosien irto-osakuvat löytyvät nettisivuilta. |
| PT | Em caso de problemas contactar o revendedor de zona, comunicando os dados gravados na chapa. Consultar o sitio web para a vista explosiva das peças sobresselentes. |





EN

Fiamma declines all responsibility for any personal injury and damage to property due to incorrect assembly or use of the product; it is suggested to keep the instructions inside the vehicle. Keep the original packaging to be used in case of return

The assembly of the product must be carried out according to the assembly instructions: the product must not be modified in any way.

All our privacy closures are made with an high quality standard.

Apart from our strict quality controls, we also have our fabrics continuously controlled by independent institutes to ensure that the fabric is tear resistant, they can hold the weight of water, the colours don't fade and it is resistant against atmospheric agents.

To guarantee a perfect quality, the fabrics are waxed or laminated several times. During this operation, single coloured pigments could move and thus create small bright spots in the material, which are only irregularities that are technically inevitable to avoid, but do not compromise the impermeability of the fabric.

Irregularities in weaving (such as knots and thickening) are due to unavoidable manufacturing tolerances and are not grounds for complaint; do not prejudice in any way the qualities of the Privacy.

Especially with light fabrics, folds may form that backlight seems dark. They are irregularities of technically unavoidable materials due to the specific workings.

MAINTENANCE INSTRUCTIONS

The formation of condensation water inside of the veranda is due to oscillations between external and internal temperature, it can be reduced by using an airtight floor and with good ventilation.

Store the Privacy closure only if it is dry and possibly clean.

The remaining humidity could cause stains. If you are forced to close it when is still wet, after max. 12 hours reopen it to make it dry.

Most of the dirt is superficial and can be removed with clean water and a cloth or a brush. If the fabric is very dirty, add some light cleaning detergent (Marseille soap). Any residual detergent on the fabric must be carefully rinsed.

Be aware never to use any aggressive chemical substances and never to clean the fabric with a high pressure machine.

Windows in transparent PVC :

Don't use detergents which contain alcohol or solvents. Wash it only with hot water and soft cloth.

Zippers: Subjected to continuous stress and wear. Open and close gently and slowly without tearing, avoiding excessive effort during fixing to the ground. Keep them sliding using a normal zipper spray.

Curtains: Wash at 30 ° C with mild detergent.

Accessories for curtains, hooks, eyelets and windscreens are items subject to wear. The duration depends on the stresses to which they are exposed.

EN Warranty Fiamma

In case of defects with regards to materials and manufacturing, the customer is entitled to the warranty in accordance with local laws and regulations of the country in which the product was purchased.

DE Garantie Fiamma

Im Falle einer Mangelhaftigkeit der Ware, kann der Verbraucher unter den erforderlichen Voraussetzungen gegenüber dem Verkäufer von dem Garantieanspruch zu den festgelegten Bedingungen gemäß den lokalen Rechtsvorschriften Gebrauch machen.

FR Garantie Fiamma

En cas d'un défaut de conformité du produit, le consommateur pourra faire valoir ses droits de recours en garantie selon les modalités prévues par les dispositions légales locales, pour autant que les conditions de recours soient satisfaites.

ES Garantía Fiamma

En caso de fallos o defectos de material y de fabricación, el cliente puede hacer valer la garantía de acuerdo con las leyes y reglamentaciones del país en el que el producto haya sido comprado.

IT Garanzia Fiamma

In caso di difetto di conformità dei beni, il consumatore potrà far valere nei confronti del venditore la garanzia secondo le modalità previste dalle disposizioni di legge locali, ove ne ricorrano i presupposti.

NL Fiamma garantie

In het geval van gebrek aan overeenstemming van de goederen kan de consument zich beroepen op de wettelijke garantie ten opzichte van de verkoper, zoals vastgelegd in de plaatselijke regelgeving, indien de omstandigheden dit rechtvaardigen.

SV Fiamma-garanti

Vid brister på varorna kan konsumenterna åberopa garantin i enlighet med lokal lagstiftning, om omständigheterna berättigar detta.

DA Garanti Fiamma

I tilfælde af defekter, hvad angår materialer og fremstilling, er forbrugeren berettiget til forhandlergarantien i henhold til lokale love og bestemmelse i det land, hvori produktet blev fremstillet.

NO Fiammas garanti

I tilfelle av defekter ved varene kan forbrukeren fremme sine rettigheter i henhold til garantien overfor forhandleren, i henhold til de reglene som er fastsatt i lokale lover, der forutsetningene for dette er til stede.

FI Fiamma-takuu

Jos tuotteiden vaatimustenmukaisuudessa havaitaan puutteita, kuluttaja voi vaatia myyjältä takuun mukaisia oikeuksia paikallisen lainsäädännön puitteissa, mikäli vaatimus on perusteltu.

PT Garantia Fiamma

Em caso de defeito de conformidade dos bens, o consumidor poderá fazer valer, em relação ao vendedor, a garantia segundo as modalidades previstas pelas disposições de lei locais, se existirem os pressupostos para tal.

Skirting

Item No. 98655-090

Tie Down S Yellow

Item No. 98655-567

Tie Down Yellow

Item No. 98655-128

Pack Organizer Privacy

Item No. 07366-01-

Kit Repair Plus

Item No. 98655-466

Tie Down S Black

Item No. 98655-133

Tie Down Black

Item No. 98655-129

Kit Magic Privacy Front

Item No. 06856-01-

Curtains Kit Smoke

Item No. 98655A483(6 pcs)
Item No. 98655A484(2 pcs)

Pack Organizer L

Item No. 07512A01-

Door Pole F45

Item No. 05161-02-

Kit Magic Privacy Side

Item No. 06856-04-

Pack Organizer S

Item No. 07512-01-

Rain Caps F45s

Item No. 06893-01-



60_IS_98690-926_revD



Fiamma S.p.A. - Italy
Via San Rocco, 56
21010 Cardano al Campo (VA)
fiamma.com

All rights reserved.
Fiamma S.p.A.
reserves the right to modify at any time,
without notice, prices, materials,
specifications and models or to cease
production of any model.