



MODEL NUMBERS:
NA-A¹-13 and NA-A¹-10

A¹ Electric Awning
13 ft | 10 ft



Compatible with all Van and RV models

Mercedes Sprinter – Wall Mounted

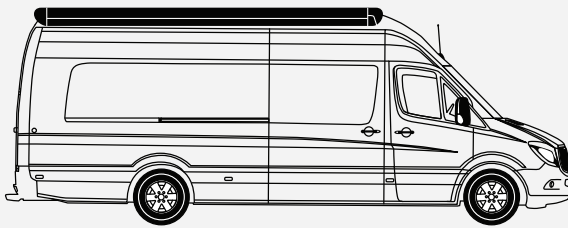

A ¹ MODEL	13'	10'
Nominal Case x Awning Extension	13.1' x 8.2'	9.8' x 8.2'
Shade Surface (@12pm Noon)	107.4ft ²	80.7ft ²
Mounting Plates	Wall (Flat Surface)	
Mounting Plates (Available Q4)	Rack (Curved Surface)	
Power	12V DC (or 24V)	
Motor	Worm-gear DC 12V (or 24V)	
Hardware Material	Heavy-Duty Aluminum	
Hardware Finish	Electrostatic Liquid Paint	
Tension Arms	Spring-loaded stainless steel chain	
Locking Mechanism	Yes	
Pitch Adjustment	5° - 15°	
Fabric Materials	460gsm Vinyllic PVC fabric	
UV Resistant	Yes/50+ (98% UV blockage)	
Water Resistance (Grade V)	50kPa of hydrostatic pressure	
Color Fastness (to Light, Rubbing)	Grade 4-5 (highly resistant)	
Anti-Fungal Growth Rating	0 (None) @ (1.1x10 ⁶)/mL	
SVHC (Hazardous Materials)	Pass @ ≤0.1% (weight for weight)	
Warranty	One (1) Year	
Light Strip	White COB LED	
Motor Wire Gauge	18AWG	

Remote Control
Included



Max Rod Extension 7.9'

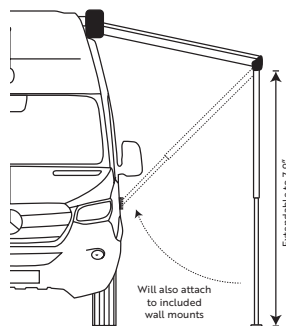

Available in 10' and 13' case lengths providing maximum shade!

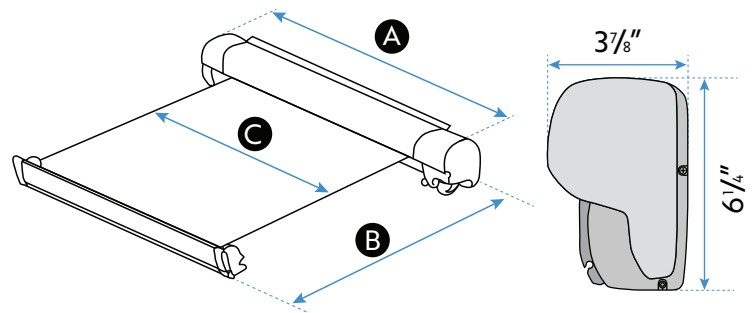

Awning Dimensions

Model	A Case Width	B Extension	C Fabric Width	Weight
NA-A ¹ -13	13.1'	8.2'	12.6'	66.8lb
NA-A ¹ -10	9.8'	8.2'	9.3'	55.8lb

User Installation Guide and Operations Manual available at NomadicCooling.com